

2011 NATIONAL BANGER SPECIFICATIONS

1. TYPE OF CAR

You must use any four wheel, right-hand drive, saloon, coupe, estate car or People Carrier in three main weight categories taken from MOT Brake Weight Chart.

- (900kg - 1250kg) e.g. Metro - Cavalier
- (1100kg - 1560kg) e.g. Cortina - Granada Estate
- (1360kg - over) e.g. Triumph 2000 – unlimited (Rear wheel drive only), except large American cars check with staging promoter.

The car must have an all-steel body, which may not be cut, lowered, narrowed or shortened. Further restrictions may apply to any weight range such as non Ford, cc limits, etc. No SUV's or 4 x 4 vehicles allowed.

2. STRIPPING

- Remove all glass and interior trim including door linings, head linings and all floor covering.
- It is compulsory to pad steering columns with high density foam.
- It is compulsory to pad the B pillar and roll cage.
- Remove all seats except the driver's which must be retained, the use of a racing seat is not allowed
- Remove all exterior trim, chrome and plastic strips, door handles, external mirrors, wheel trims and weights
- Remove over riders from both front and rear bumpers
- Remove any towing bar or towing attachments, spare wheel carriers
- Original fuel tanks must be removed. If however, the tank is an integral part of the body you must remove as much as possible.
- Only the original standard steel bumper can be used. If a front bumper is fitted, a maximum of three additional bolts may also be fitted to secure it in place. No wrap around bumpers allowed. Plastic bumpers must be removed. All cars with **deep impact style bumpers** must have the bumper and retaining irons removed before racing e.g.; Volvo 2 series, **late style Mondeo, Focus and Saab, you may fit a Cortina type bumper in it's place.**
- **Vectras, Mk1 or Mk2 Mondeos must have all bumpers removed – these MUST NOT be replaced with a Cortina type bumper. In addition the bolting of front wings is not allowed on these models.**

3. ROLL BAR

- You must fit a single "hoop" roll bar in support of the door pillars, securely bolted to the roof and floor with a minimum size bolt of 3/8" (8mm) and suitable washers.
- The roll cage must be fitted upright or dog-legged, but not leaning back or forward.
- It is compulsory to pad roll cages, including the B pillar.
- The hoop must be one piece or two uprights on one top bar of a welded construction.
- One cross bar is compulsory, a second is optional; these must be welded or bolted to the upright
- **THE ROLL BAR MUST NOT HAVE ANY REAR SUPPORTS but may have extensions no further forward than the B post (see diagram below). If used, it is recommended that this is bolted through the B post.**

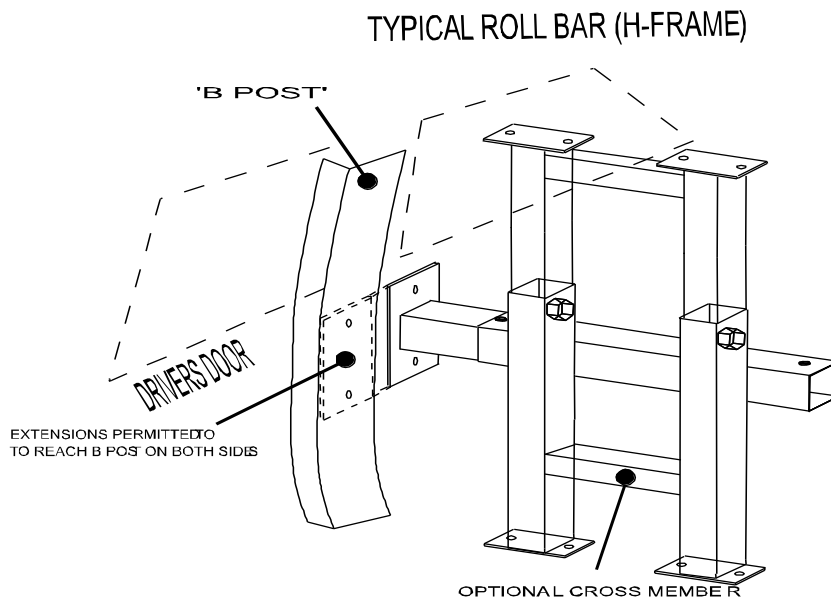

- **It is highly recommended that the frame is bolted through both sides of the car.**
- The minimum size for roll bar is 2" (50mm), maximum size 4" (100mm), minimum thickness 3mm.
- Crossbars must have a 5" (125mm) square end plate fitted. This must be minimum 6mm thick.
- The roll bar cross bars must be straight, or extended forward to the B pillar and bolted through the pillar
- Each upright must have a **minimum** of two bolts on each side to the floor and one each side at the top.
- You must tie the seat at shoulder level to the roll cage or B pillar, through the seat frame not headrest, you may fit the 2nd cross bar in support of the seat just below the window aperture or weld a frame on the cage to support the seat at the top.

4. STRENGTHENING

- All doors must be secured shut.
- The driver's door may be welded with no restriction on the amount of welding used. Box section is allowed in the lower window aperture of the drivers and rear drivers door, not extending further than the rear of the H frame. **Please note that this is not allowed on the passenger side.**
- All other doors must be secured by bolting or chains. Maximum number of bolts permitted is 4 per door.
- Where plates are used to secure doors other than the drivers door, then these must be a maximum of 12" x 12" (300mm x 300mm) and fitted with a maximum of 5 bolts, minimum size 1/4" (6mm)
- Triangular corner plates or straps may be used to secure the rear of the bonnet by bolting or welding (1/8" thick). Plates or straps must be placed no further than 20" (500mm) across or down from the back edge and side of the bonnet.
- Bonnets must be bolted down using a maximum of four bolts, 2 bolts in either side of the bonnet, with a minimum of 18" between the front and rear. Maximum height of bolt above the washer is 1 1/2" (37.5mm). Bonnets must not be moved forward or overlapped.
- These bolts must not pass through the chassis or be attached to the suspension bed with the exception of cars that are manufactured as standard without inner flitches (e.g. Vectra) On such cars the bolts may pass through the chassis.
- Front bolt must go through the slam panel or inner wings and you may use crush tubes, when crush tubes are used, they must be a maximum of 2" (50mm) outside diameter tube.
- Rear crush tubes may be secured in place by one bolt but not welded. Front crush tubes cannot be secured by either bolting or welding.
- Crush tubes may be a maximum of 2" (50mm) outside diameter tube or 2" (50mm) box, maximum 5mm wall thickness.
- Crush tubes and washers must be separate items, i.e. the tube cannot be welded to the washer.
- Maximum size of bolt or studding is 1" (25mm), including shouldering. Cam wheels may not be used as bonnet washers. Maximum size of the washer is 7" (175mm) x 5" (125mm)
- Maximum length of chain if used is 24" (60cm).
- Shuttering bolts may only be used for bonnet bolts providing they only protrude past the top of the wing nut by 1/2" (12mm), and are taped up to ensure they do not come loose. These are not recommended and may not be allowed by some promotions – please check with the promotion.
- Boot lids or rear door on estates may be chained or bolts using a maximum of four bolts, one in each corner, maximum size 3/8" (9mm) or 24" (60cm) of chain.
- All cars must start the meeting with the wings covering each wheel.
- **Front wings may be folded and 2 additional bolts may be added to secure the wing, however this is not allowed on Vectras or Mk1 or Mk2 Mondeos.**
- **A maximum of 2 additional bolts are allowed on rear wings/wheel arches.**
- All cars should have the complete dashboard removed if possible. You may be required to make an additional brace to secure the steering column, however this is mandatory if the standard support is removed i.e. cross bar on a Mondeo.
- No screen bars allowed.
- The scrutineers have the right to refuse any car which has more welding or bolts than necessary. The driver must present his car for scrutineering with the bonnet and bolts but they must NOT be fixed to the car.
- You are not allowed to strengthen the gearbox tunnel.
- Expanding foam or any other material may not be used to fill chassis or door sills etc.
- Sunroofs must be bolted **or welded**. If covered, the maximum thickness of the plate is 1/8" (3mm), the maximum size of the plate is 4" (100mm) larger than the sun roof opening. ~~If a plate is fitted it must not be bolted to the roll cage.~~
- You may strengthen the TCA (the steering adjustment arm on the steering rack) by welding or sleeving.
- You may strengthen the bottom arm, but this must remain standard in dimension and re-positioning of the ball joint is not allowed.
- Suspension legs may be welded to the hub.
- No additional strengthening of any other suspension parts is allowed.
- Ford Granada or Cortina type sub frames may be secured with washers; Jaguar or Rover Coupe type sub frames may be secured by bolting or tack welding to the width of the mounting only.
- Where relevant, a crank sensor protector may be fitted to a maximum size of 2" x 2" (50mm x 50mm) angle iron, 4" long (100mm), maximum 2 bolt fixing, secured to the bell housing/engine.

- **You may fit a distributor guard to the following specification but it is only permitted on engines with a front facing distributor, i.e. 'A' series engine or Toyota Crown.**
- **The maximum size of the guard is 9" x 9", with a maximum thickness of ¼". The plate may be bolted or braced using box iron, no bigger than 1" x 1" or welded TO THE ENGINE ONLY, I.E you CANNOT fit the guard to the sub-frame or gearbox.**
- **Cars that fail post or pre-race scrutineering, found to be armoured or strengthened, including engine or gearbox suspensions mounts that are over the top will receive an immediate 12 month ORCi ban. This also includes distributor and cam belt guards.**

5. DOOR PLATES & FLOOR PLATES

- A steel plate 10" to 15" deep 3/8 – ¾" thick must be bolted over the drivers door. This must be fitted with a minimum of 3" and a maximum of 6" past the A & B pillars securely bolted with a minimum of 4 bolts. There must be at least 1 bolt through the A pillar and one must be through the B pillar or through the roll cage. The bolt size must be at least 16mm studding or bolt (Only flat plate is allowed, no channel, angle or corrugated steel allowed). 8mm is the smallest size bolt allowed on all other bolts except A & B pillar.
- For 2 door cars (no B Pillar), the door plate MUST be bolted through the roll cage.
- A steel plate fitted to the drivers floor pan is highly recommended. It must be no thicker than 6mm, and must be bolted and/or welded in. This may be modified to rise to the maximum height of the sill of the door side only.
- A 4" steel plate no thicker than 6mm bolted through the A pillar to the door plate can be welded or bolted to the floor plate. It is not permitted to cut slots in the driver's doorplate, holes for bolts only.

6. FUEL SYSTEM

- Manual fuel pumps may be replaced with electric pumps.
- The original petrol tank must be removed and replaced with a maximum size 2-3 gallon safety tank fitted inside the car on, under or behind the roll bar, but not on the parcel shelf. Before fitting, the tank should be carefully checked to see that it cannot leak when inverted or on its side and the outlet must be from the top of the tank. The vent pipe from the top of the tank must be terminated below the floor level of the car. The fitting of a one way valve is advisable.
- All fuel lines must be in good condition and securely clamped.
- **With carburettor fuelled cars, a manual shut-off tap must be fitted within reach of the driver when strapped in the car, but with fuel injected cars, the fuel flow must be controlled by the pump cut off switch. Immersed fuel pumps are permitted.**
- All fuel tanks must have a metal screw top.

7. ELECTRICAL SYSTEM

- Batteries must be bolted or clamped in position and completely covered with rot-proof material to prevent acid leakage. Batteries should be fitted on, under or behind the roll bar, not in the footwell. If batteries are secured in a box the maximum size is to be 18" x 12" or equivalent.
- Alternators, if fitted, cannot be wired to charge.
- All wiring must be fully insulated.
- Electrical starters must be fitted and in working order.
- **Ignition and starting must be activated through an insulated switch, not by connecting bare wires together. A battery cut off switch MUST be mounted on the roll cage on the near side of the car, the switch must be wired to the earth side of the battery.**
- Electronic ignition is permitted within the manufacturers range e.g. Ford – Ford.
- **Engines that are fitted with ignition system relying on a flywheel sensor (or similar), must not be modified to use a gear driven distributor.**

8. COOLING SYSTEM

- Any modifications must be within the original bonnet outline.
- L shaped water tanks must end 6" behind the front of the engine block on rear wheel drive vehicles.
- Oblong and L shape tanks must not be fitted in front of the engine, the tank must be no further forward than 2" from the front face of the head on front wheel drive vehicles.
- These tanks must only be secured by 4 fixings and may not be welded into the car.
- Tanks along the bulkhead may only be extended in an L shape on one side of the engine.
- The front of the engine is classed as the block not the pulleys or water pumps etc.
- **The water pump may be removed and blanked off, however, if the water pump remains fitted, it must not be protected in any way – i.e you must not fit a protective guard.**
- No cutting of bulkheads allowed.
- Tanks must be non-pressurised.
- An overflow pipe, minimum size ½", must be fitted on the driver's side and terminate within 9" of the floor on the driver's side.
- The bonnet must not be cut or altered to fit water tanks.
- Any car or light commercial radiator may be used, fitted under the bonnet.
- Water outlets may be modified but not armoured.

9. ENGINES, GEARBOX, PROPSHAFTS & EXHAUST MANIFOLDS

- The engine and gearbox must be the one originally fitted to the range as manufactured.
- The external parts of the engine must remain standard.
- The internal parts of the engine may be modified.
- Engine and Gearbox mountings may be replaced or strengthened, but must occupy the original fixing positions.
- Vernier wheels are allowed.
- Additional gearbox mounts are only allowed on rear wheel drive cars. On front wheel drive gear box mounts must occupy the original position but can be strengthened.
- Flywheels may be modified.
- Clutches are free.
- The MK1 - MK2 & MK3 Granada's are allowed to interchange the V6 Engines and gearboxes.
- Propshafts may be modified
- Charging system, power steering pumps, air-conditioning pumps and fan blades may be removed.
- **No turbos or superchargers**
- No dry sump systems.
- A complete metal firewall must exist between the driver and engine compartment.
- **No armoured cam or water outlets.**
- Any standard cast exhaust manifold which fits the engine may be used.
- Cars which are produced with a fuel injected engine may be used fitted with the same or smaller size carburettor engine from an earlier range i.e. The Ford Mk 3 Granada may be used supplementing the 2.9ltr with the 2.8 or 2ltr engine with carburettor.
- **Any Ford Pinto, Duratec or Zetec up to 2 Litre engine and gearbox (fitted with the standard carburettor) may be used in any RWD car as long as this is no larger than the original engine.**
- Engine mounts may be strengthened but must remain in the original place if fitted. No additional mounts allowed. Modified mounts can be welded to the cross member, but must be bolted if attached to the chassis.
- On transplanted engines the position of the mounts on the engine are free, but the rule on chassis or cross member mounts is as above. **The purpose is to hold the engine and not strengthen the car. Every part must be behind the front of the engine and not used for armouring.**
- No additional metal is allowed on the chassis to mount the engine, and engine mounts must not protect water outlets or distributors etc
- Top left engine mount on a Mondeo must be of the same size as the original.

10. CARBURETTOR/INLET MANIFOLD

- Fuel injection engines may be converted to carburettors if the engine is manufactured in both forms as standard. Inlet manifolds may be modified or self manufactured items e.g. the 2.9 V6 can be used with the 2.8 inlet and carburettor, or Cavalier with the earlier style inlet manifold.
- **Fuel injections may be modified to carburettor using a manufactured or adapted inlet manifold and must run with one standard downdraft Weber type carburettor to a maximum size or equivalent 38 DGAV eg Pierburg, Solex, Weber – NO MULTIPLE CARB SETUPS.**
- Carburettors may be replaced with the equivalent size Weber conversion as per specification below. Adapter plates may be fitted by bolting or welding (max size carburettor allowed is **38DGAV as fitted to the 3.0 Litre V6 or 2.8 carburettor.**
- **Vehicles fitted with fuel injection can be used providing they are fitted using the standard banger fuel system and the fuel pump is replaced with a standard high pressure pump, or submersible pump. Suitable high pressure fuel lines must be used between the fuel pump and the injection system.**
- Cold starting devices may be removed.
- Jets may be changed.
- Replacement Spindles with standard screws may be fitted, no polishing or reproofing allowed, no modifying or enlargement of any fuel galleries allowed.
- Floats must not be modified or weighted and needle valve must remain standard size, enrichment or power valve must be fitted and working.
- Note: The Solex or Pierburg carburettor may be replaced with the equivalent size Weber conversion as above specification
- All carburettors must have a visual secondary fixing on the fuel inlet pipe.
- Air filters may be removed or replaced by competition type.

11. WHEELS AND TYRES

- Any standard steel or alloy wheel up to 6 ½"J that fits safely may be used.
- You may only use conventional road tyres up to 195. On unlimited meetings only, conventional road tyre up to 235 may be used. Tyre gaiters are allowed.
- All tyres should have a minimum durometer reading of 60, whenever tested.
- No Yokohama, Avon 7.3 wide safety, town and country, M & S, Toyo, Kingpin Alpine Series competition type or cut tyres. All wheel nuts must be fitted. The ORCi reserve the right to ban any tyre make or type which give an unfair advantage.
- The use of Weller style steel wheels to the max size of 6½ J are permitted on any car.

- Cut and shut or banded wheels are not permitted.
- **All identification markings to remain on tyres. Any tyre with buffed markings will not be accepted, and will be subject to disciplinary action.**

12. SUSPENSION, BRAKES AND AXLES

- Suspension components must remain standard, lowering is allowed by cutting, heating or changing of springs only.
- Shock absorbers must be standard type as fitted originally. No interchanging of suspension parts allowed.
- Bump stops may be removed and the only adjustment allowed are those which can be achieved within the manufacturers original design. Cross members must not be altered or re drilled
- All suspension mounts must be in the original position.
- Brakes must be effective.
- ~~Back axles can be interchanged with light commercial type and must be fitted on top of springs.~~
- Camber must not be altered from standard, race damage must be proven and this will not be tolerated on new cars. The Scrutineers decision is FINAL.
- Bluebird or similar car may use a strap connecting the two wishbones on shale or dirt tracks.
- A secondary fixing is required on coil springs that may fall out, chain or wire should be used - not welding.
- The tack welding of anti-roll bar brackets is allowed.
- All suspension rubber mounted tops may be secured with a larger washer than original. These must not be welded.

13. DIFFERENTIALS

- Ratios are free but must be standard to the range.
- No limited slip differentials allowed, even if fitted as standard.
- Power locked differentials are allowed if fitted as STANDARD to the car, and NOT as an optional extra.
- Differential must be unlocked except on shale or dirt tracks.
- Axle casings must not be welded or reinforced.

14. EXHAUST SYSTEMS

- Tubular exhausts maybe fitted if standard to that model
- Wherever possible the original exhaust system must be retained with the last 600mm removed
- If the original system has to be replaced, there must be at least one silencer to each exhaust pipe and at least two secondary fixings after the manifold. No Cherry Bombs or straight through systems are allowed.
- The original mount must be supplemented with at least one additional fixing to secure the system to the car.
- No car will be allowed to race without an exhaust system and all drivers must be aware that if your car is above the required noise level you will not be allowed to race.

15. SAFETY EQUIPMENT

- A full shoulder-type safety harness as approved by ORCi for Bangers with lap-straps must be fitted and bolted to the floor.
- A minimum of a four point buckle fixing must be used with a minimum of 3 floor fixings. A secure part of the floor or cage (including the seat bar), are recommended anchor points.
- Single point buckle fixing harnesses are not allowed.
- A suitable head restraint must be fitted to the roll cage or seat.
- A 1Kg Dry Powder Gauge Fire Extinguisher is highly recommended and if fitted, this should be in a tube with a spring top and should be within easy reach of the driver. Old type BCF (green) type extinguishers are not allowed. All tow vehicles, must carry a minimum of a 2kg fire extinguisher dry powder or gas, which must be within easy reach of the driver and mechanics at all times, especially when refuelling.
- **Helmets must be of a minimum standard as directed by British Oval Racing Safety Executive (B.O.R.S.E). These are BS6658 Type A/FR, FIA8860-2004, Snell SA2005, Snell SA2010, SFI Foundation 31.1A, SFI Foundation 31.2A. The E2205 European standard helmet may be used in Fibreglass, Carbon or Tri-Composite form only i.e. NO POLYCARBONATE helmets are allowed. It is important that the helmet fits the driver correctly. Shatterproof goggles/visors must be worn although tinted visors are not advisable. Your helmet must display the current ORCi (ORC10) sticker.**
- Neck braces are recommended.
- Fireproof Balaclavas are highly recommended and must be marked appropriately.
- Fireproof gloves are **MANDATORY** and must be marked appropriately.
- Only flame retardant racing suits must be worn. On wet meetings waterproofs may be worn as overgarments.
- The drivers seat must be secured and supported to the roll cage at shoulder level by bolting or tying.
- The 2nd roll cage cross brace may be used to support the seat, but it must be set below the bottom of the window aperture or you may construct and weld a frame on to the cage to support the seat.
- The drivers seat must be a standard production seat, not a racing seat.

16. NUMBERS

- You must fit a fin plate to the roof of your car, minimum size 18" x 12" and a maximum size of 20" x 15".
- Your number must be either white on a black background or black on a white background, no other colours allowed, no other writing allowed, minimum size 9" high x 1½" wide. If your number is not to the above specification, you may not be lap scored.
- You **MUST** paint your number on each side of the car in contrasting colours.

17. ROOF GRADES

- Your grade colour must be painted on the whole roof of your car.

18. SUPPLEMENTARY RULES (For Special Meetings)

Your promoter will state either via the fixture list or special entry form at which meetings this rule can be used and therefore cannot be used by a driver regardless of type of car at a normal meeting!!

On Unlimited Meetings.

- ◆ You may replace the standard engine with any engine provided it is the same or smaller cc
- ◆ ***Back axles ONLY can be interchanged with light commercial type and must be fitted on top of springs.***
- ◆ ***Front suspension can only be altered with car derived parts***

On Middle Range Meetings.

- ◆ ***Any Ford Pinto, Duratec or Zetec engine up to 2 Litre engine and gearbox may be used fitted with the standard carburettor.***

On the Lower Weight Range.

- ◆ The 1300cc Ford Crossflow or o.h.c. engine and gearbox fitted with the standard carburettor may replace the standard engine.
- ◆ Engine mounts may be strengthened but must remain in the original place if fitted. No additional mounts allowed. Modified mounts can be welded to the cross member, but must be bolted if attached to the chassis.
- ◆ On transplanted engines the position of the mounts on the engine are free, but the rule on chassis or cross member mounts is as above. **The purpose is to hold the engine and not strengthen the car. Every part must be behind the front of the engine and not used for armouring.**
- ◆ No additional metal is allowed on the chassis to mount the engine, and engine mounts must not protect water outlets or distributors etc.

SUSPENSION AND STEERING

- ◆ Left hand drive cars may be allowed at the staging promotions discretion.

19. VAN MEETINGS

- ***Roll cages must be a minimum of one acrow bar up to a maximum of a full roll cage. If the single bar option is used, it must be fitted centrally behind the driver's seat, plated top and bottom, minimum 4 bolts per plate. A full roll cage is recommended on fibreglass bodies and flat fronted vans, so as to help protect the drivers feet. If fibreglass type body, then the door plate can be welded to the rollcage on the drivers side. The driver's seat must be secured at shoulder height to the door pillars or cage, if fitted. Each promotion may have additional regulations – please check.***
- ***An engine guard is permitted on cam belt or forward facing distributor type engines. This is to protect the engine only and not to add strength to the van. The scrutineers decision is final.***
- ***Vans with independent chassis, the rear end must be removed back up to the rear spring hanger, to allow the body to collapse.***
- ***If it is not possible to fit a water tank within the National Banger rules above, the local Promoter may allow the fitment elsewhere within the car. Water tank rule must be down to the promoter running the meeting if a water tank cannot be fitted to the national rules.***

20. METRO/MICRO BANGERS

- All usual rules apply and additionally you may fit a distributor guard to the following specification
- The maximum width of the guard is 9", with a maximum thickness of ¼".
- The plate may be for the full depth of the engine, bolted or welded to the sub-frame and or gearbox and at the top braced back to the front of the head using box iron, no bigger than 1" x 1", it is only permitted to use a distributor guard on a front facing distributor, i.e. 'A' series engine.
- Metro rear sub-frames may be secured by an additional two bolts as a secondary fixing.

21. FINAL PREPARATION

- The external painting of the car should be in bright colours. Any colour schemes are permitted. Rusty or dirty vehicles will not be allowed out onto the circuit. Rude or provocative slogans are not allowed. In addition to the car construction rules, all cars presented at scrutineering must be considered safe and not unsightly.
- ***New undersealing of the underside of the car is strictly forbidden.***

2011 2 LITRE BANGER SPECIFICATIONS

All cars must be built to the current ORCi National Banger specifications with the following additional rules:

Type of Car

You may use any 4 wheel, 4 cylinder, right hand drive saloon, estate or coupe with a maximum original engine size of 2000cc, on the weight range taken from the MOT Brake Weight Chart : 1100Kg – 1560Kg (Middle Weight Range).

Please note the following cars are not permitted

Consul, Granada, Mercedes, Scorpio, Toyota Cressida, Large Volvo, Zephyr or Zodiac

Additional cars may be allowed at the Promoters discretion. Please telephone the event Promoter to check

GENERAL BANGER RACING RULES

- 1. Helmets must be of a minimum standard as directed by British Oval Racing Safety Executive (B.O.R.S.E). These are ~~BS6658 Type A/FR~~, FIA8860-2004, Snell SA2005, Snell SA2010, SFI Foundation 31.1A, SFI Foundation 31.2A. The E2205 European standard helmet may be used in Fibreglass, Carbon or Tri-Composite form only i.e. NO POLYCARBONATE helmets are allowed. Shatterproof goggles/visors must be worn although tinted visors are not advisable. Your helmet must display the current ORCi (ORC10) sticker.***
2. Flame retardant racing suits are compulsory. Neck braces are recommended. Fireproof Balaclavas are highly recommended and must be marked appropriately. Fireproof gloves are **MANDATORY** and must be marked appropriately.
3. All flag signals must be obeyed immediately.
4. Drivers who appear to have indulged in the intake of alcohol or drugs will be excluded from racing. Smoking is not permitted in cars, on track or in the pits at any time.
5. No passengers are allowed in the car. The driver may only travel on the car on a parade or lap of honour.
- 6. Banger racing is a full contact sport; drivers can race to win or attempt to win by stopping the opposition. **The Stewards interpretations and decisions on these rules are FINAL.** All heats, consolations and finals must be in one direction only. **Certain Promotions allow turning around on the bends, however, this does not allow a driver to drive the wrong way down the straights. A driver should always check with the Promotion exactly what rules apply at that meeting.** The driver can push or spin any car towards the infield or fence, but should not be in contact with the front car if it hits the fence, this may be deemed to be a forceful fencing or follow in, and both offences carry a ban. You must not attack any car on the safety area, or attack from the safety area. **Any serious breaches of the safety area rule will mean an automatic 3 month ORCi Ban.** You must not attack any cars after the red flag or if the stationery yellow is displayed above a car or if the race is under caution (Waved yellow). You must not attack an empty or overturned car. Any damaging collision with a driver's door will result in a penalty. **T-boning cars which are against or close to the Armco with excessive force is not allowed. Please note that you can still hit cars positioned against the Armco over the front or rear wheels.*****
7. Demolition type events. Any race where the nature of the event is to stop the opposition to win the following rules apply attacking from the opposition direction is permitted providing the attack is from the outside of the track (fence side). You are also allowed to wait for car or attack any part of the car except the driver area, which is considered to be from the centre of the front wheel to the centre of the rear door driver's side.
8. Demolition Derby rules may only be used when the staging promoter declares by way of drivers briefing, letter or notice in the programme that these rules apply.
9. Drivers who abandon their car during a race while a race is in progress must retire to a recognised safety area.
10. It is an offence to put or attempt to put an overturned car back onto its wheels during a race, drivers are not allowed to re-enter a car once they have left it. Repairs are not allowed on the circuit and car must not be pushed or handled in any way during a race.
11. Team tactics in an individual event will be subject to penalty the decision of the steward will be final.
12. A driver will be held responsible for his or her mechanics or helpers at all times. Drivers will be bound by the decision of the officials in all matters (these two items are a condition of booking).
13. Drivers must carry his or her log book at all times.
14. It is an offence for two drivers to share a car at the same meeting; you may only race one car at a meeting unless the promotion allows it as an option for special events.
15. All cars, trim, glass and wheels must be removed from the stadium directly after the meeting.
16. In all events the racing must be on track indicated, drivers who try to gain advantage by corner cutting will be penalised or disqualified. Also drivers who continue to drive on and off the safety area will be disqualified.
17. Drivers must comply with any reasonable instruction given by an official of the meeting, failure to do so will result in a penalty or disqualification.
18. Mechanics are not allowed onto the circuit or to repair any competing car. Mechanics are allowed onto the track by invitation of the Clerk of the Course or the Racing Manager only to take part in parades or lap of honour for trophy winners.

REVISED RULES FOR 2011 IN BOLD/ITALIC PRINT

ITEMS MARKED ~~STRIKETHROUGH~~ ARE NO LONGER ALLOWED

2011 National Banger Technical Specifications, Issue 2, Dated 13th December 2010